

MULTITIMER Multifunction Relay MK 7850N/200



Your Advantages

- Up to 10 functions in one unit
- Simplified storage
- Increased flexibility
- Quick setting of long time values

Features

- According to IEC/EN 61 812-1
- 8 functions settable via rotational switch:
 - Delay on energisation (AV)
 - Fleeting on make (EW)
 - Delayed pulse (IE)
 - Flasher, start with pulse (BI)
 - Delay on de-energisation (RV)
 - Pulse forming function (IF)
 - Fleeting on break (AW)
 - Delay on energisation and de-energisation (AV / RV)
- 8 time ranges from 0.02 s to 300 h selectable via rotational switches
- Voltage range AC/DC 12 ... 240 V
- With time interruption / time adding input for all functions
- Suitable for 2-wire proximity sensor control
- 2 changeover contacts, one programmable as instantaneous contact
- LED indicators for operation, contact position and time delay
- Wire connection: also 2 x 1.5 mm² stranded ferruled, or 2 x 2.5 mm² solid DIN 46 228-1/-2/-3/-4
- as option with pluggable terminal blocks for easy exchange of devices
 - with screw terminals
 - or with cage clamp terminals
- 22.5 mm width

Circuit Diagrams

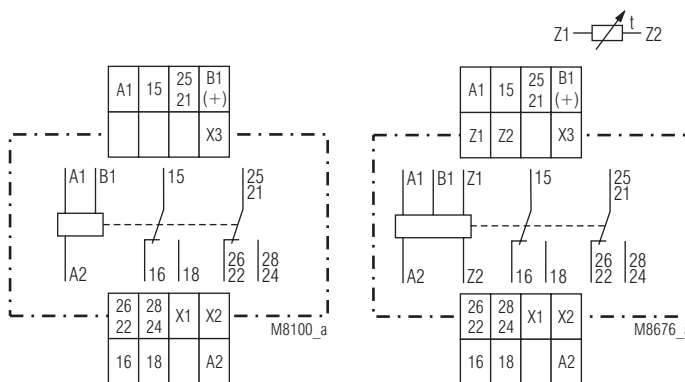

MK 7850N.82/200

MK 7850N.82/300

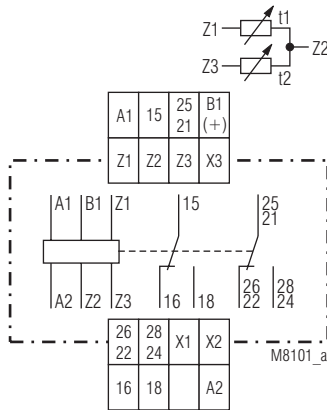

MK 7850N.82/500

MK 7850N/500: as MK 7850N/200 but with

- 2 additional functions:
 - Cyclic timer, start with break (TP)
 - Fleeting on make and break (EW / AW)
- second time setting t_2 for functions
 - Cyclic timer, start with pulse (TI) or break (TP), based on the separate setting of pulse and break time the flasher function can be used as cyclic timer
 - Fleeting on make and break (EW/AW)
 - Delay on energisation and de-energisation (AV / RV)
 - Delay pulse (IE) and setting of pulse length
- Connection facility for 2 external potentiometers

Approvals and Markings



* see variants

Application

Time dependent controls for industrial and railway applications.

Indicators

green LED:	on when voltage connected
yellow LED "R/t":	shows status of output relay and time delay:
-Continuously off:	output relay not active;
	no time delay
-Continuously on:	output relay active;
	no time delay
-Flashing (short on, long off)	output relay not active;
	time delay
-Flashing (long on, short off)	output relay active;
	time delay

Function Diagram

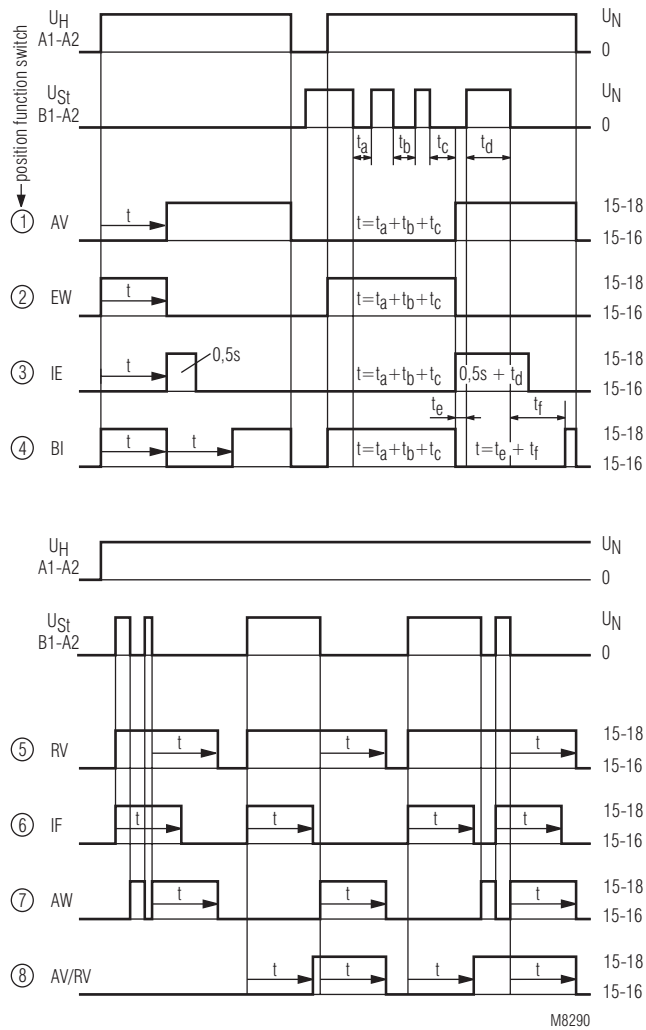

MK 7850N/200

① ... ⑧ = position of function switch

- | | |
|----------------------------------|---|
| ① AV = Delay on energisation | ⑤ RV = Delay on de-energisation |
| ② EW = Fleeting on make | ⑥ IF = Pulse forming function |
| ③ IE = Delayed pulse | ⑦ AW = Fleeting on break |
| ④ BI = Flasher, start with pulse | ⑧ AV/RV = Delay on energisation and de-energisation |

Function Diagram

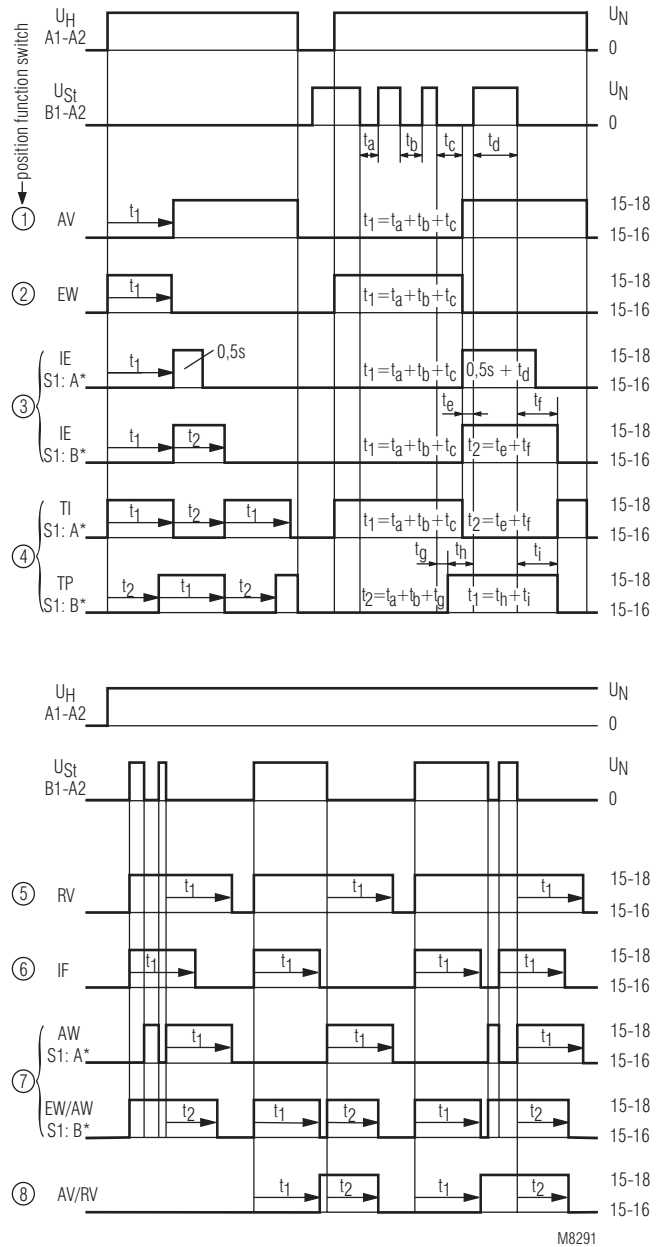

MK 7850N/500

① ... ⑧ = position of function switch

- | | |
|---|--|
| ① AV = Delay on energisation | ⑤ RV = Delay on de-energisation |
| ② EW = Fleeting on make | ⑥ IF = Pulse forming function |
| ③ IE = Delayed pulse | ⑦ AW = Fleeting on break |
| S1 in position A:
t1: adjustable, t2 = 0.5 s fixed | S1 in position A
EW/AW = Fleeting on make and break |
| S1 in position B:
t1 and t2 adjustable | S1 in position B |
| ④ TI = Cyclic timer, start with pulse
S1 in position A | ⑧ AV/RV = Delay on energisation and de-energisation |
| TP = Cyclic timer, start with break
S1 in position B | |

Connection Terminals	
Terminal designation	Signal designation
A1, A2	Auxiliary voltage
B1(+), A2	Control input (various control possible, depending on the time function)
X1, X2	Control input (2. delayed C/O contact or instantaneous contact) X1/X2 not bridged: 2 nd delayed C/O contact 25-26-28 X1/X2 bridged: 2 nd instantaneous C/O contact 21-22-24
X3, X2	Control input (Time interruption/time adding) X3/X2 bridged: Time interruption X3/X2 not bridged: continued time delay (with time adding)
Z1, Z2	Input for connection of a external potentiometer for time setting t1
Z3, Z2	Input for connection of a external potentiometer for time setting t2
15, 16, 18	1 st C/O contact (delayed)
21, 22, 24, 25, 26, 28	2 nd C/O contact (delayed), if X1/X2 not bridged 2 nd C/O contact (instantaneous), if X1/X2 bridged

Notes

Control of A1-A2 with proximity sensors

The input can be controlled by DC 3 wire or AC/DC 2 wire proximity sensors. For operating voltage > 24 V and usage of sensors without built-in short circuit protection a protection resistor on A1 is recommendend to reduce the inrush current. The dimension is as follows:

$R_v \approx$ operating voltage / max. switching current of sensor

The series resistor must not be selected higher than necessary.

Max. values are:

Operating voltage: 48 V 60 V 110 V 230 V
Series resistor R_v max: 270 Ω 390 Ω 680 Ω 1.8 k Ω (1 W)

Instantaneous contact

By external wire links the output function of the device can be altered from 2 delayed contacts to 1 delayed **and** 1 instantaneous contact. The contact 25-26-28 is delayed without bridge on X1-X2, it is instantaneous with bridge on X1-X2. The legend term is 21-22-24. The instantaneous contact switches when the operating voltage is connected. To terminals X1 and X2 no other voltage potentials must be connected, as the unit might be damaged.

Adjustment assistance

The flashing period of the yellow LED is $1 \text{ s} \pm 4 \%$ and can be used to adjust the time. Especially on the lower end of scale and for long times it is suitable as the multiplication factors between the different time ranges are exact without tolerance.

Example:

The required time is 40 min. It has to be adjusted within range 3 ... 300 min. The time check takes too long as several timing cycles would be necessary for a precise value. For faster adjustment the setting is made to 0.03 ... 3 min. On this range the potentiometer should be set to 0.4 min (= 24 sec.). With the right potentiometer setting the LED must show 24 flashing cycles. After that the time range is switched over to 3 ... 300 min. and the setting is complete.

Time interruption / time adding with B1

With the functions AV, EW, IE and BI the time delay can be interrupted by controlling input B1 (+) with control voltage. Removing the control signal will continue the timing cycle (time addition).

Notes

Control input B1

The functions RV, IF, AW, AV / RV have to be controlled via input B1 (+) with voltage against A2. The control signal could be the same as the auxiliary/control voltage of A1 or any other voltage between 12 and 240 V AC or DC. Operating a parallel load between B1 and A2 is also possible.

If with function IF the inputs A1 and B1 are controlled simultaneously a pulse with the adjusted length is started. With the variant MK 7850N/500 the output pulse can be disabled by setting the slide switch in Position "B".

Time interruption and time addition with X3

On all functions, also with RV,IF, AW (EW/AW) and AB/RV the time delay can be interrupted during timing by bridging the terminals X2 - X3. By opening the bridge the time continues (time addition). While X2 and X3 are bridged the control input is disabled and the yellow LED remains in the state it had at stop. No external voltage must be connected to X2 and X3 as the unit may be damaged.

Remote potentiometers

Both settings on variant MK 7850N/500 can also be made by remote potentiometers of 10 kOhms:

- terminals Z1 - Z2: potentiometer for time t1
- terminals Z2 - Z3: potentiometer for time t2

When connecting a remote potentiometer the corresponding potentiometer has to be set to min. If no remote potentiometers are required the terminals Z1-Z2 resp. Z2-Z3 have to be linked.

The wires to the remote potentiometers should be installed separately from the lines with mains voltage. If this is not possible, a screened cable is recommendet where the shield is connected to Z2.

To terminals Z1, Z2 and Z3 no external voltage must be connected, as the unit might be damaged.

Additional function

With the variant MK 7850N/500 additional features can be selected for the functions position 3, 4 and 7 using the slide switch S1 on the relay front in position "B". At the same time a second time setting t2 is available on the lower potentiometer (see Function Diagram) the time range is the same as for t1.

Setting

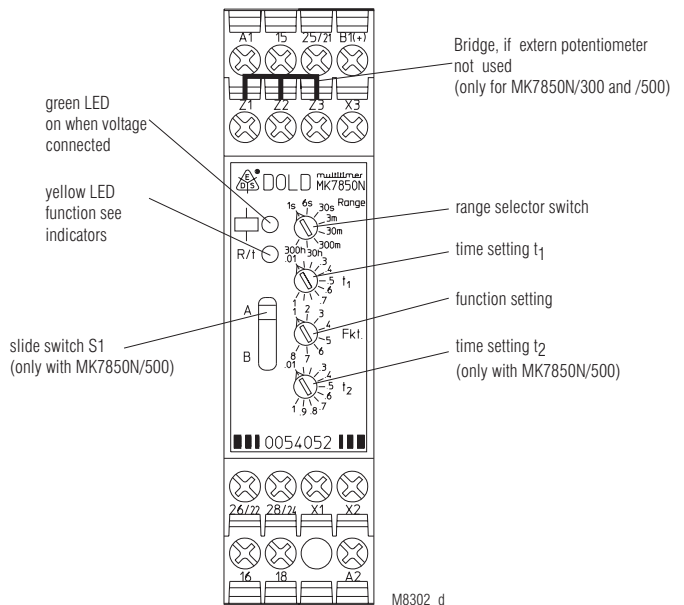

Attention

If no remote potentiometers at MK 7850N/500 are required the terminals Z1-Z2 resp. Z2-Z3 have to be linked.

Technical Data

Time circuit

Time ranges:	8 time ranges in one unit, settable via rotational switch
	0.02 ... 1 s 0.3 ... 30 min
	0.06 ... 6 s 3 ... 300 min
	0.3 ... 30 s 0.3 ... 30 h
	0.03 ... 3 min 3 ... 300 h
Time setting t1, t2:	continuous, 1:100 on relative scale (t2 only at MK 7850N/500)

Recovery time:	
at DC 24 V:	approx. 15 ms
at DC 240 V:	approx. 50 ms
at AC 230 V:	approx. 80 ms
Repeat accuracy:	± 0.5 % of selected end of scale value + 20 ms

Voltage and temperature influence:	< 1 % with the complete operating range
---	---

Input

Nominal voltage U_N:	AC/DC 12 ... 240 V
Voltage range:	0.8 ... 1.1 U _N
Release voltage (A1/A2)	
	Delayed contact
AC 50 Hz:	approx. 7.5 V
DC:	approx. 7 V
	Instantaneous contact
AC 50 Hz:	approx. 3 V
DC:	approx. 3.3 V
Max. permitted residual current with 2-wire proximity sensor control (A1-A2)	
up to AC/DC 150 V:	AC resp. DC 5 mA
up to AC/DC 264 V:	AC resp. DC 3 mA
Control current B1:	approx. 1 mA, over complete voltage range
Min. on/off time of control input B1(+):	
AC 50 Hz:	approx. 15 ms / approx. 60 ms
DC:	approx. 5 ms / approx. 60 ms
Release voltage (B1/A2)	
AC 50 Hz:	approx. 3.5 V
DC:	approx. 3 V
Nominal power consumption	
AC 12 V:	approx. 1.5 VA
AC 24 V:	approx. 2 VA
AC 240 V:	approx. 3 VA
DC 12 V:	approx. 1 W
DC 24 V:	approx. 1 W
DC 240 V:	approx. 1 W
Nominal frequency:	45 ... 400 Hz

Output

Contacts	
MK 7850N.82:	2 changeover contacts, one programmable as instantaneous contact:
without bridge X1-X2:	25-26-28 delayed changeover contact
with bridge X1-X2:	21-22-24 instantaneous contact at U _N on A1-A2
Contact material:	AgNi
Measured nominal voltage:	AC 250 V
Thermal current I_{th}:	see quadratic total current limit curve (max. 4 A per contact)
Switching capacity	
to AC 15	
NO contact:	3 A / AC 230 V IEC/EN 60 947-5-1
NC contact:	1 A / AC 230 V IEC/EN 60 947-5-1
to DC 13 at 0.1 Hz:	1 A / DC 24 V IEC/EN 60 947-5-1
Electrical life	IEC/EN 60 947-5-1
to AC 15 at 1 A, AC 230 V:	1.5 x 10 ⁵ switching cycles
Permissible switching frequency:	36 000 switching cycles / h
Short circuit strength	
max. fuse rating:	4 A gL IEC/EN 60 947-5-1
Mechanical life:	≥ 30 x 10 ⁶ switching cycles

Technical Data

General Data

Operating mode:	Continuous operation
Temperature range	
Operation:	- 40 ... + 60 °C (higher temperature see quadratic total current limit curve)
	- 40 ... + 70 °C
Storage:	93 % at 40 °C
Relative air humidity:	< 2.000 m
Altitude:	
Clearance and creepage distances	
rated impulse voltage / pollution degree:	4 kV / 2 (basis insulation) IEC 60 664-1 III
Overvoltage category:	
Insulation test voltage, type test:	2.5 kV; 1 min
EMC	
Electrostatic discharge:	8 kV (air) IEC/EN 61 000-4-2
HF-irradiation	
80 MHz ... 1 GHz:	20 V / m IEC/EN 61 000-4-3
1 GHz ... 2.7 GHz:	10 V / m IEC/EN 61 000-4-3
Fast transients:	2 kV IEC/EN 61 000-4-4
Surge voltages between wires for power supply:	2 kV IEC/EN 61 000-4-5
between wire and ground:	4 kV IEC/EN 61 000-4-5
HF-wire guided:	10 V IEC/EN 61 000-4-6
Interference suppression:	Limit value class B EN 55 011
Degree of protection	
Housing:	IP 40 IEC/EN 60 529
Terminals:	IP 20 IEC/EN 60 529
Housing:	Thermoplastic with V0 behaviour according to UL subject 94
Vibration resistance:	Amplitude 0.35 mm, frequency 10 ... 55 Hz, IEC/EN 60 068-2-6 40 / 060 / 04 IEC/EN 60 068-1 EN 50 005 DIN 46 228-1/-2/-3/-4
Climate resistance:	
Terminal designation:	
Wire connection	
Screw terminals (integrated):	1 x 4 mm ² solid or 1 x 2.5 mm ² stranded ferruled or 2 x 1.5 mm ² stranded ferruled or 2 x 2.5 mm ² solid
Insulation of wires or sleeve length:	8 mm
Plug in with screw terminals	
max. cross section for connection:	1 x 2.5 mm ² solid or 1 x 2.5 mm ² stranded ferruled
Insulation of wires or sleeve length:	8 mm
Plug in with cage clamp terminals	
max. cross section for connection:	1 x 4 mm ² solid or 1 x 2.5 mm ² stranded ferruled
min. cross section for connection:	0.5 mm ²
Insulation of wires or sleeve length:	12 ±0.5 mm
Wire fixing:	Plus-minus terminal screws M 3.5 box terminals with wire protection or cage clamp terminals
Wire fixing:	Box terminals with wire protection
Fixing torque:	0.8 Nm
Mounting:	DIN rail IEC/EN 60 715
Weight:	approx. 150 g

Dimensions

Width x height x depth	
MK 7850N/200:	22.5 x 90 x 97 mm
MK 7850N/200 PC:	22.5 x 111 x 97 mm
MK 7850N/200 PS:	22.5 x 104 x 97 mm

Classification to DIN EN 50155

Vibration and

shock resistance: Category 1, Class B IEC/EN 61 373

Ambient temperature: T1, T2 compliant
T3 and TX with operational limitations

Protective coating of the PCB: No

UL-Data

Switching capacity:

Ambient temperature 60°C: Pilot duty B300
5A 250Vac G.P.

60°C / 75°C copper conductors only

Screw terminals fixed: AWG 20 - 12 Sol/Str Torque 0.8 Nm

Plug in screw: AWG 20 - 14 Sol Torque 0.8 Nm

AWG 20 - 16 Str Torque 0.8 Nm

Plug in cage clamp: AWG 20 - 12 Sol/Str



Technical data that is not stated in the UL-Data, can be found in the technical data section.

CCC-Data

Switching capacity:

to AC 15

NO contact: 1.5 A / AC 230 V



Technical data that is not stated in the CCC-Data, can be found in the technical data section.

Standard Types

MK 7850N.82/200/61 AC/DC 12 ... 240 V

Article number: 0056618

- Output: 2 changeover contacts, one programmable as instantaneous contact

- Nominal voltage U_N : AC/DC 12 ... 240 V

- Time ranges: from 0.02 s ... 300 h

- Width: 22.5 mm

Variants

MK 7850N.82/300: 8 functions with connection facility for 1 remote potentiometer 10 k Ω (t1).

MK 7850N.82/500: second time setting t2, connection facility for 2 remote potentiometers 10 k Ω to adjust t1 and t2,
2 additional functions selectable via slide switch S1:
- Cyclic timer, start with break (TP)
- Fleeting on make and break (EW/AW)

Ordering example for variants

MK 7850N .82 / /61 AC/DC 12 ... 240 V

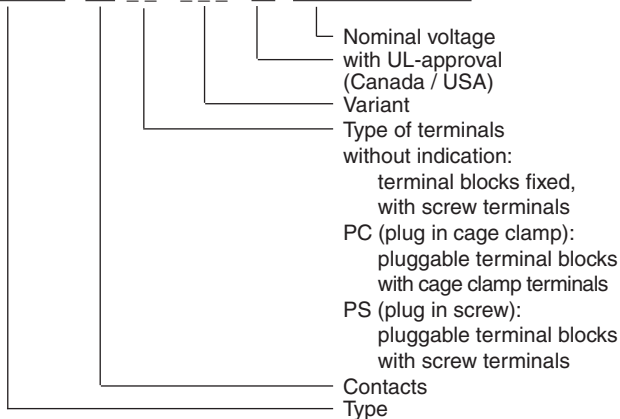

Options with Pluggable Terminal Blocks

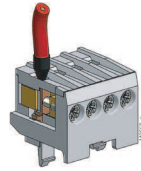

Screw terminal (PS/plugin screw)

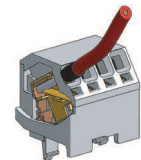

Cage clamp (PC/plugin cage clamp)

Notes

Removing the terminal blocks with cage clamp terminals

1. The unit has to be disconnected.
2. Insert a screwdriver in the side recess of the front plate.
3. Turn the screwdriver to the right and left.
4. Please note that the terminal blocks have to be mounted on the belonging plug in terminations.

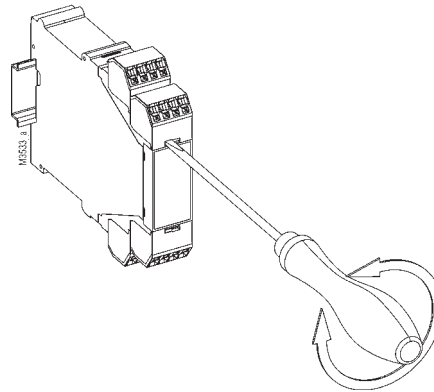

Characteristic

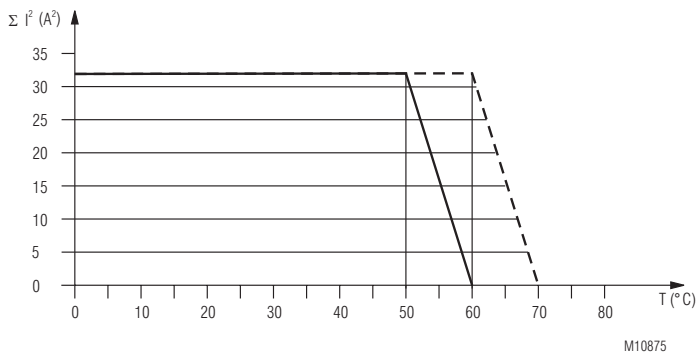

--- device mounted away from heat generation components.

— device mounted without distance heated by devices with same load.

quadratic total current limit curve

Accessories

AD 3: External potentiometer 10 kΩ
Article number: 0028962

The external potentiometer is used for remote setting of the time delay. The internal potentiometer of the timer must be set to min. time delay.

Degree of protection front side:

IP 60

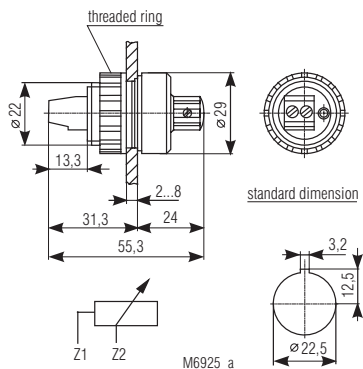

Connection Examples

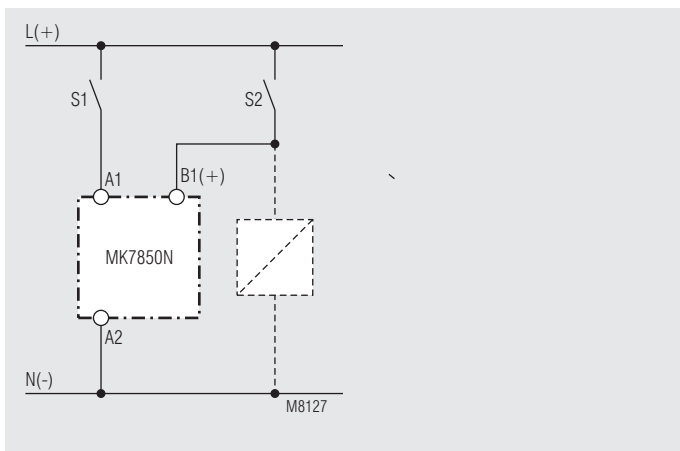
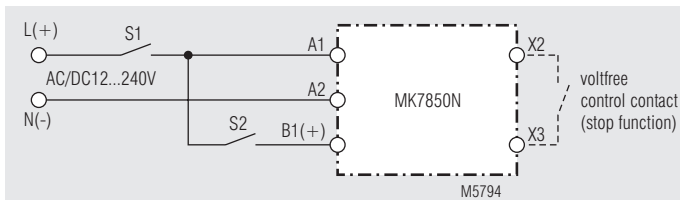

Control with parallel connected load

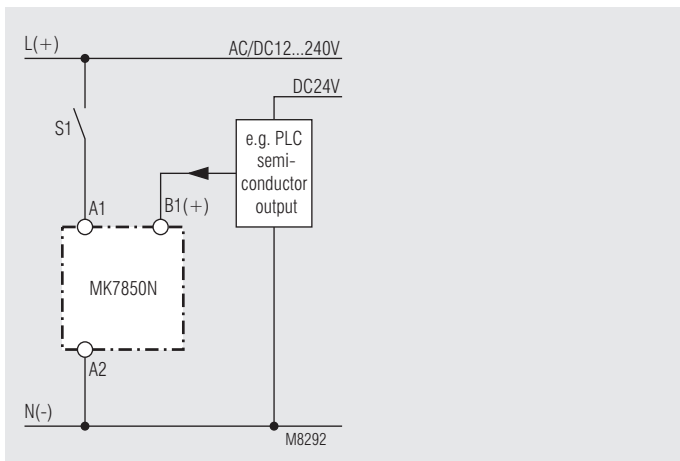

Connection with 2 different control voltages.